



Japan

Sole Agent :



PT. LUMBUNG TEKNOLOGI ENVIROTAMA

Submerged Mechanical Aerator/Agitator

AQUARATOR®

Ministry of Construction (Current Ministry of Land, Infrastructure, Transport and Tourism)
Technology Assessment (Assessment No. 81102)

KIRANA TWO OFFICE TOWER 17th - 18th FLOOR

Jl. Boulevard Timur No. 88 Kelapa Gading
Jakarta Utara 14240

Telp. : 021 - 2962 9767

Fax. : 021 - 2962 9769

HANSHIN ENGINEERING Co., Ltd.

The Most Advanced Aerator and Agitator in the World Hanshin Aquarator

The Hanshin Aquarator is the original aerator and agitator and it is also
the pinnacle of the technology.

Since the invention of the world's first, energy conserving
aerating/agitating equipment in 1975, Hanshin has continued to provide
technological innovations to pioneer a new future for people and water.
The Hanshin Aquarator is the embodiment of these ideas and technology
at their highest levels.

AQUARATOR®



Proven deliveries of 10,000 units to 1000 processing locations.

The Aquarator has advanced the benchmark value of aerator/agitator equipment in Japan through its use in numerous locations.

Ideas that don't change with time, technological advancements that are ahead of their times.

The true ideals of aerator/agitator equipment can be seen in the Hanshin Aquarator:



*Proven deliveries to sewage treatment plants, night soil treatment plants, and rural community sewage treatment facilities (as of March, 2010)

The highest standards and performance in the industry

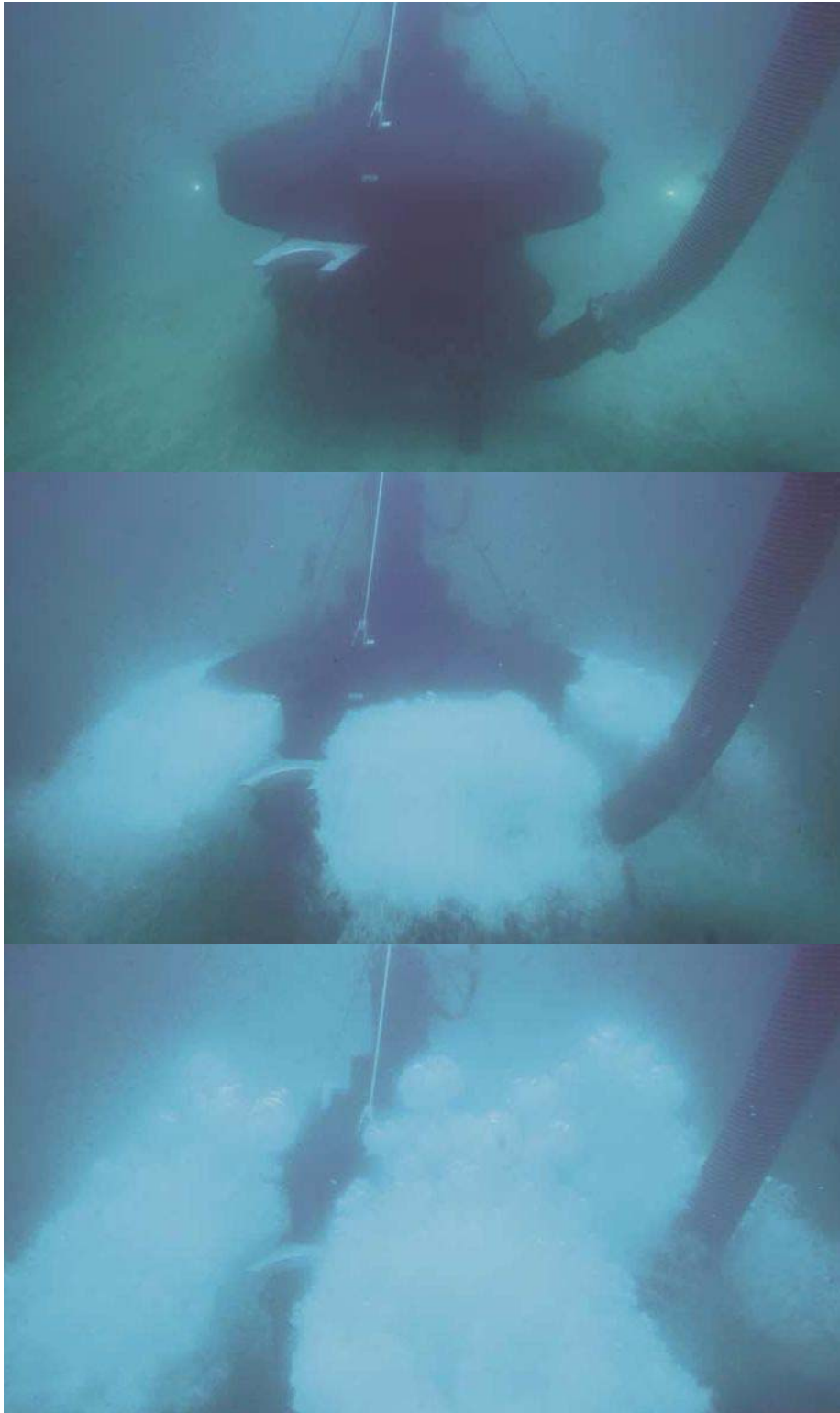

By separating the power sources for the aerating and agitating functions, the Aquarator can easily conform to any changes in load, eliminate wasteful energy consumption and has made possible drastic reductions in water processing costs.

Aeration over long distances and wide areas with an oblique flow discharge

By lowering the discharge angle, the discharge is now an oblique flow discharge. Thanks to this, the microbubble compound liquid can be carried further; the water flow circulation is increased, and has made possible aeration in even the deepest sections of water.

Increased discharge strength through petal-shaped segmentation

By segmenting the water discharge route into petal shapes, discharge strength has been significantly increased.

Bottom inflow increases the time air bubbles are contained within the tank

The natural flow of air and water dramatically increases power efficiency. In addition, by generating bottom inflow strength, water is sucked into the bottom of the tank without separation and surfacing of the air bubbles, and forces entrainment with the water flow. Through this, the time the air bubbles are contained within the tank is increased.

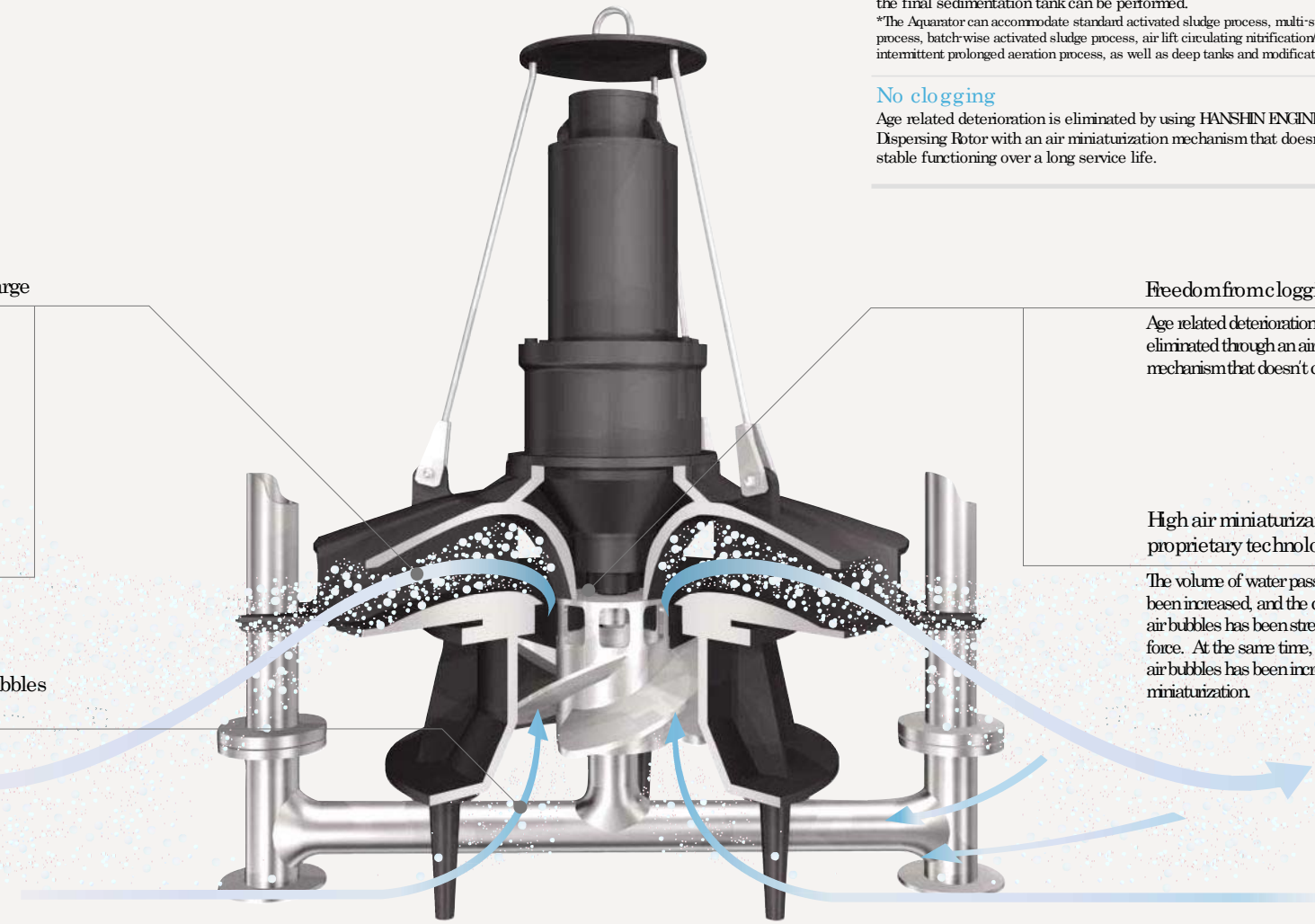

Freedom from clogging

Age related deterioration of performance is eliminated through an air miniaturization mechanism that doesn't clog.

High air miniaturization through proprietary technology

The volume of water passing through the body has been increased, and the diffusion strength of the air bubbles has been strengthened by centrifugal force. At the same time, the contact area of the air bubbles has been increased through air bubble miniaturization.

Realization of extremely high energy efficiency

By separating the power sources for the functions of supplying air and aeration/ agitation to create rational submerged equipment, energy efficiency is drastically increased by being able to arbitrarily control both functions at the same time, or each function separately.

Easy maintenance

Due to its simple design, maintenance can be performed on-site. This also dramatically decreases the time required for maintenance. In addition, because the Aquarator is simply placed along a guide pipe, water draining is not required when installing or removing the Aquarator.

Accommodates various processing methods

By separating power sources, the Aquarator can act as a submerged agitator for both aerobic and anaerobic agitation, as well as accommodating various processing methods such as aerobic and anaerobic activated sludge process. Reliable solid-liquid separation in the final sedimentation tank can be performed.

*The Aquarator can accommodate standard activated sludge process, multi-stage aerobic and anaerobic process, batch-wise activated sludge process, air lift circulating nitrification/denitrification process, intermittent prolonged aeration process, as well as deep tanks and modifications to the installed tank.

No clogging

Age related deterioration is eliminated by using HANSHIN ENGINEERING's proprietary Air Dispersing Rotor with an air miniaturization mechanism that doesn't clog. This provides stable functioning over a long service life.

*Agitation functions have been improved through design changes.

A submerged aerobic and anaerobic aerator/agitator that accommodates numerous processing methods

- The Aquarator can flexibly accommodate numerous processing methods.
- Freely choose installation methods depending on the provided environment.
- The Aquarator can change shape according to the shape of the tanks and consistently provides the highest level of performance.

Overall configuration

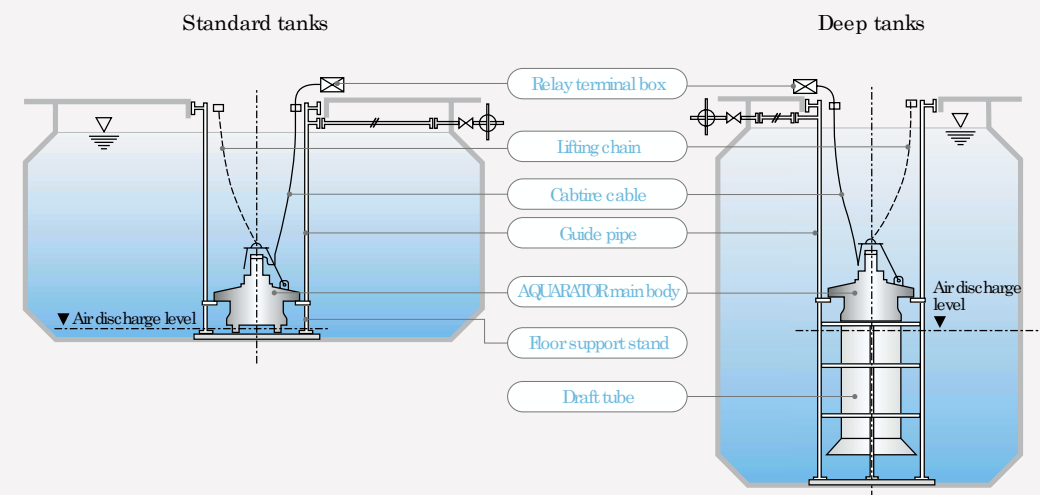

The Aquarator separates the power sources for the 2 main functions for aeration which are the supplying of air and agitation/aeration. By creating rational submerged equipment for the latter, the energy efficiency of aeration has been greatly increased. [Ministry of Construction (Current Ministry of Land, Infrastructure, Transport and Tourism) Technology Assessment No. 81102]

By separating the control factors for the air supply function and the aeration/agitation functions, the Aquarator can act as a submerged agitator for both aerobic and anaerobic agitation, as well as being able to easily select between various processing methods such as standard activated sludge process, aerobic and anaerobic activated sludge process, intermittent prolonged aeration process, batchwise process.

The separation of the control factors (power source) means the Aquarator can easily accommodate changes in water processing conditions and processing methods in an energy efficient manner. Depending on the circumstances and purpose, the unit can use either the air supply function (blower) or the aeration/agitation functions (Aquarator) separately or both controlled arbitrarily to be able to perform appropriate processing even under heavy loads.

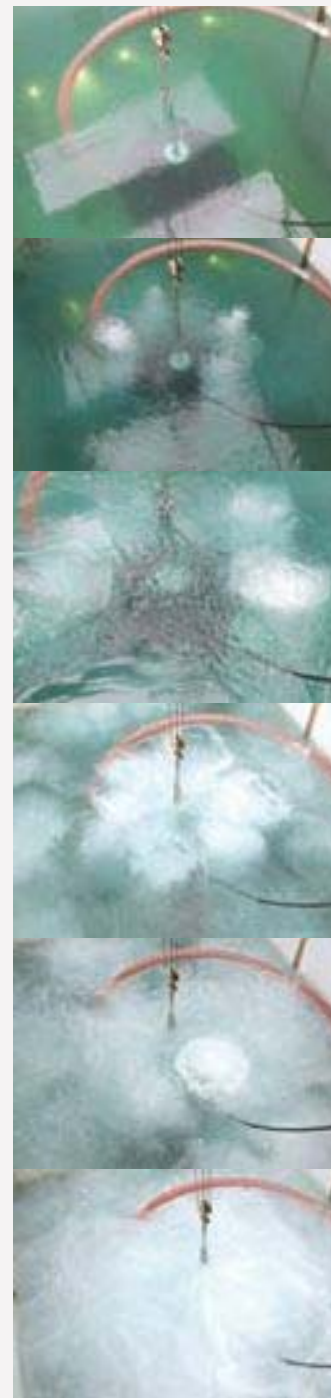

Transitioning from traditional aeration equipment

- The Aquarator can flexibly accommodate different tank shapes and operational methods for reliable processing.
- The Aquarator, which is for both anaerobic and aerobic use can not only act as aeration equipment, but its capabilities also fully shine as an agitator as well.**
- The Aquarator can also be used as reinforcing agitator for other aeration equipment.
- The Aquarator can solve various problems such as low levels of DO (Dissolved Oxygen) in the tanks as well as reduced functionality due to accumulation of sediment and clogging.**

Transition from Surface Aerators

Surface Aerator

- **Lack of agitation at bottom of tank**
 - Sedimentation of sludge
 - Reduction of tank volume
 - Reduction of aeration time
 - Reduction of processing capabilities
 - Rist and stink occurs
 - The tank bottom becomes hypoxia easily
- **Dispersion of sewerage mist**
The mechanism design makes dispersion of sewerage mist unavoidable

Complete integrated agitation possible

Accurately and reliably supplies oxygen to efficiently aerate the tank and improve tank DO levels.

Since aeration is performed in the water, there is no need to worry about water spray, noise or foul smells.

Uniform agitation within the tank as well as the surface is possible. There is also no accumulation of sediment.

The Aquarator also has no problems with deep tanks that surface aerators find difficulty with.

Transition from Diffuser Pipes, Diffuser Tubes, and Diffusion Plates

Diffuser pipe / Diffuser tube / Diffusion plate

- **Sedimentation of sludge**
Because of a swirling flow of air bubbles, the flow velocity is attenuated in areas at the bottom of the tank which are furthest away from the outlet, making it easier for sediment to accumulate
- **Progression of clogging**
 - Clogging progresses when the volume of air decreases following a change in load
 - Clogging due to inverted pressure when aeration is stopped

Reliable aeration and agitation with the Aquarator

High power aeration and agitation even at the bottom of the tanks so that there is no accumulation of sediment

Turbulent flows are generated by the strong outlet flow from the Aquarator. Larger amounts of oxygen can be dissolved since the air bubbles last longer.

Clogging does not occur because of stoppage of aeration in intermittent processes or when the volume of air decreases.

High rigidity that supports unsurpassed aeration/agitation functions and a body that produces superior water flow



Custom developed air miniaturization mechanism, the "Air Dispersing Rotor"

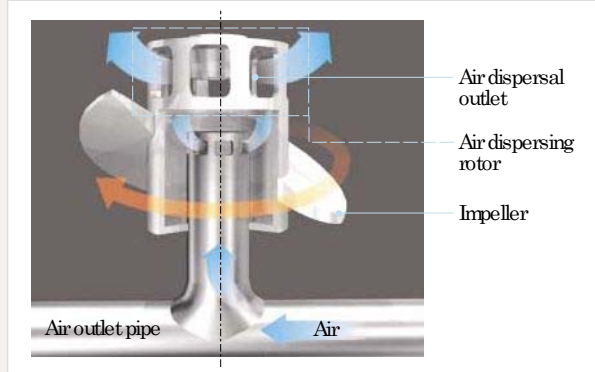

Exterior engineering drawing

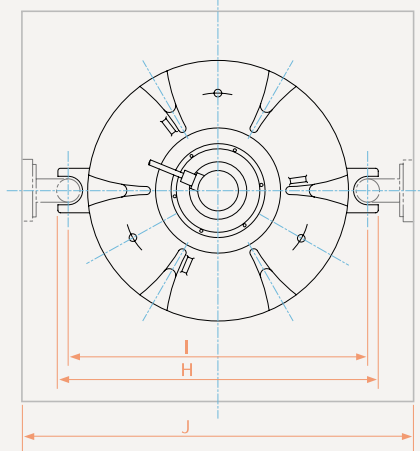
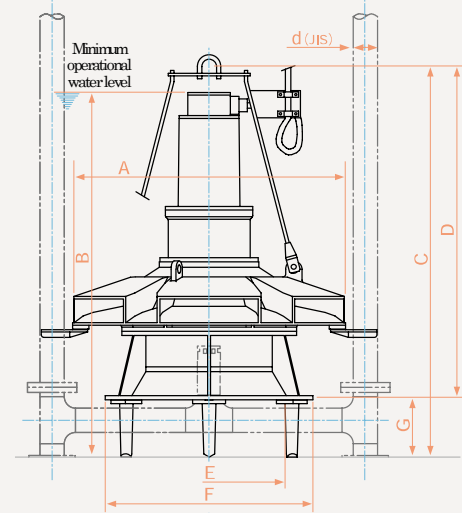

An extensive lineup to accommodate various environments

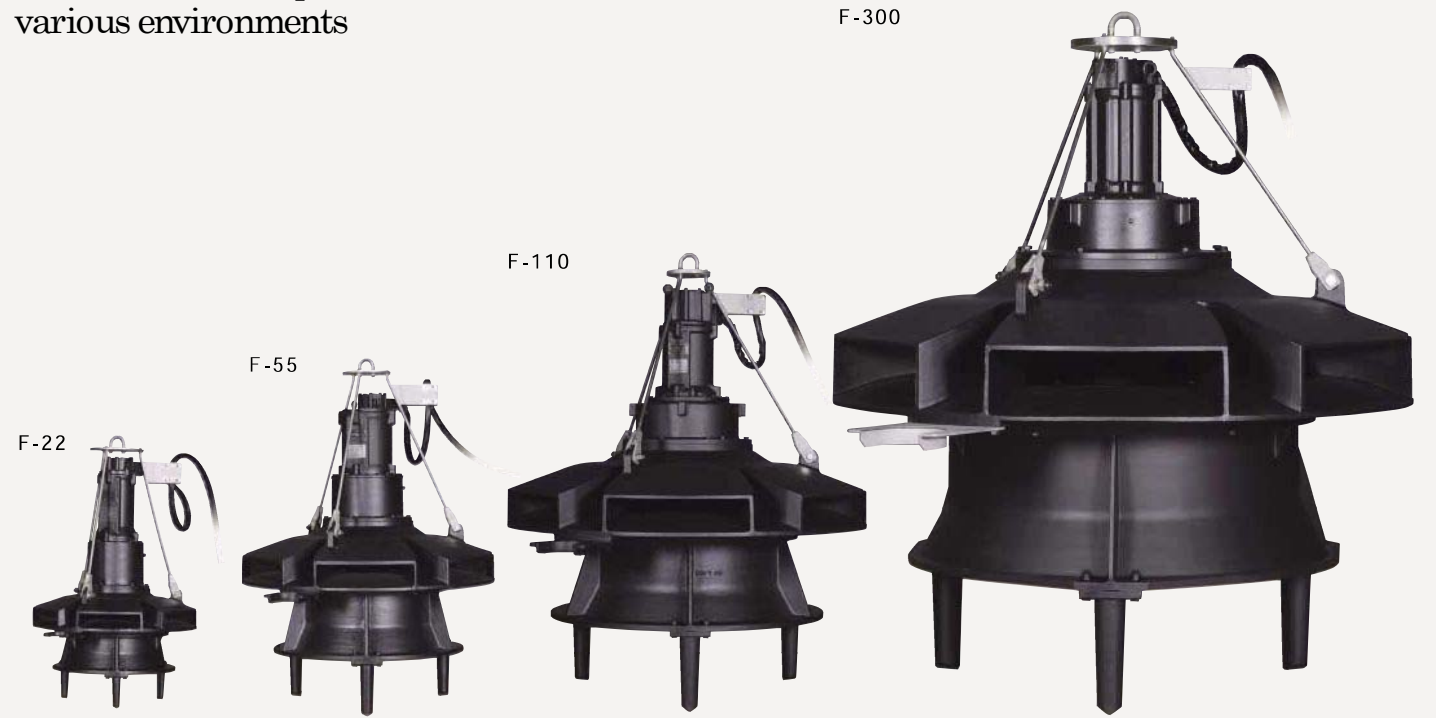

Exterior measurements

Model	Main measurements (mm)											Specified weight (kg)	Rating			Performance		
	A	B	C	D	E	F	G	H	I	J	d (JIS)		Power (kW)	Voltage (V)	Frequency (Hz)	Water pumping volume (m ³ /min)	Air flow volume (m ³ /min)	Oxygen transfer rate (kg-O ₂ /h - reference)
F-15	800	1,123	1,259	1,099	500	600	160	970	910	1,200	50A	295	1.5	200 / 220	50	12	1.7	6.5
F-22	800	1,184	1,259	1,099	500	600	160	980	910	1,200	65A	310	2.2			14	2.5	9.3
F-37	1,000	1,340	1,430	1,220	640	760	210	1,230	1,150	1,500	80A	460	3.7	380 / 400	60	24	4.2	16.1
F-55	1,220	1,490	1,617	1,362	780	920	255	1,470	1,370	1,750	100A	690	5.5			38	6	24
F-75	1,420	1,762	1,865	1,565	910	1,080	300	1,750	1,630	2,050	125A	1,100	7.5	440		52	8	33
F-110	1,720	1,916	2,040	1,680	1,110	1,310	360	2,070	1,920	2,350	150A	1,650	11			80	12	49
F-150	2,000	2,125	2,430	2,005	1,290	1,530	425	2,400	2,250	2,750	150A	2,450	15			110	17	67
F-220	2,380	2,550	2,670	2,155	1,560	1,840	515	2,910	2,710	3,250	200A	3,300	22			160	25	97
F-300	2,600	2,850	2,980	2,380	1,810	2,110	600	3,400	3,150	3,750	250A	4,500	30			220	35	132

Rating and Performance

* Please note that dimensions, weight, specifications and exterior design are subject to change without notification.

*The displayed oxygen transfer rates are for when the reference installation water depth is 5.0m.
*Please consult HANSHIN ENGINEERING for voltage other than these above.

Unparalleled standard performance, realizing stable aeration performance

When selecting a model, the number of units and air flow volume, both the agitation and the oxygen supply capabilities within the tank needs to be satisfied. In regards to oxygen supply capability, the design requirements for Actual Oxygen Requirement (AOR) of the compound liquid within the tank is calculated at 20°C and adjusted for freshwater condition values. The Standard Oxygen Transfer Rate (SOTR), required by the submerged aeration/agitation equipment, is then determined and an appropriate model with the appropriate air flow volume is selected from the capability chart.

Regarding agitation capability

Agitation capability refers to the water flow generation capability required to sustain the mixed suspension of activated sludge. The required power output for each tank is calculated and the smallest appropriate model is selected.

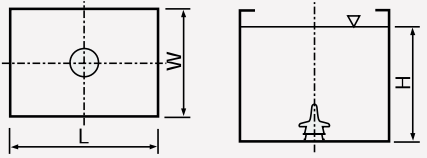
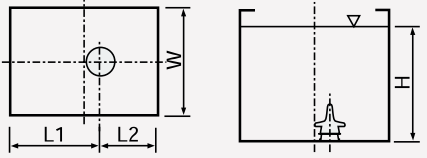
Case A		$V=L \times W \times H \text{ (m}^3\text{)}$	Design standard value ※1 Required agitation power density $P_o \text{ (kW/m}^3\text{)}$ Standard tank / Deep tank ※2
Case B		When $L1 > L2$ $L=2 \times L1 \text{ (} L1 > L2 \text{)}$ $V=L \times W \times H \text{ (m}^3\text{)}$	
			Required power output $P_r \geq P_o \times V \text{ (kW)}$

*1 Design standard values are for sewerage/reaction tanks.
*2 Deep tanks are those with draft tube specifications.

Selection examples that are outside selection condition ranges

Example 1 Standard tank
Model: F-22 Aquarator (2.2kW)
Tank size: 9m (length) x 9m (width) x 6m (depth) ($P_o \approx 4.5W/m^3$)

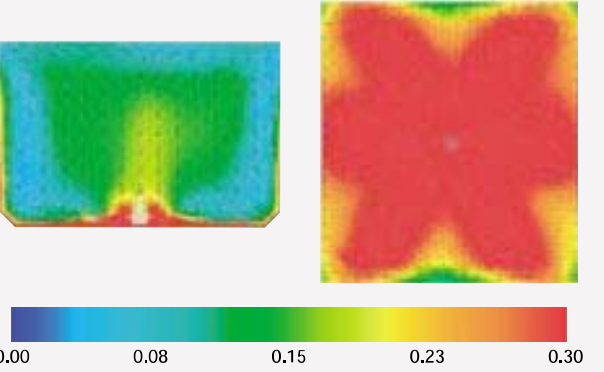

Average flow speed (m/sec)
Cross sectional flow speed in center of unit / flow speed at base of unit

Example 2 Deep tank
Model: F-37 Aquarator (3.7kW)
Tank size: 9m (length) x 9m (width) x 10m (depth) ($P_o \approx 4.6W/m^3$)

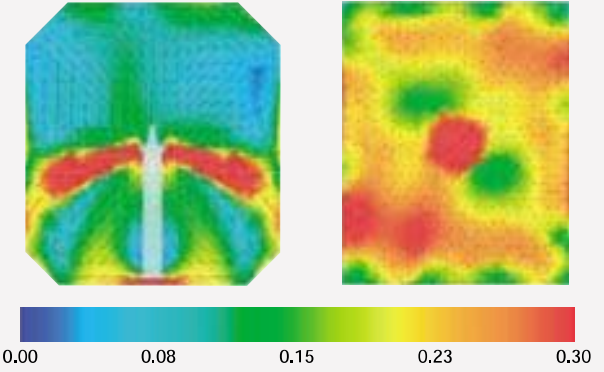

Average flow speed (m/sec)
Cross sectional flow speed in center of unit / flow speed at base of unit

*If there are joists or columns in the tank, the required agitation power density may differ (depending on the installation location of the equipment).
*Please contact HANSHIN ENGINEERING if there are any large decentralizations of equipment installation location or if the selection conditions do not match.

Oxygen transfer capability chart When operating on commercial electrical power

The following charts illustrate oxygen transfer rates during commercial operation (freshwater 20°C, MLD0=0mg/L).
*When selecting air flow volume, please do so while including some leeway as oxygen transfer rates can fluctuate approximately 10% depending on water temperature, tank shape/size and inflowing water substrates.
*The standard installation water depth is based on the distance from the water surface to unmoving parts of the equipment (bottom of lower casing).

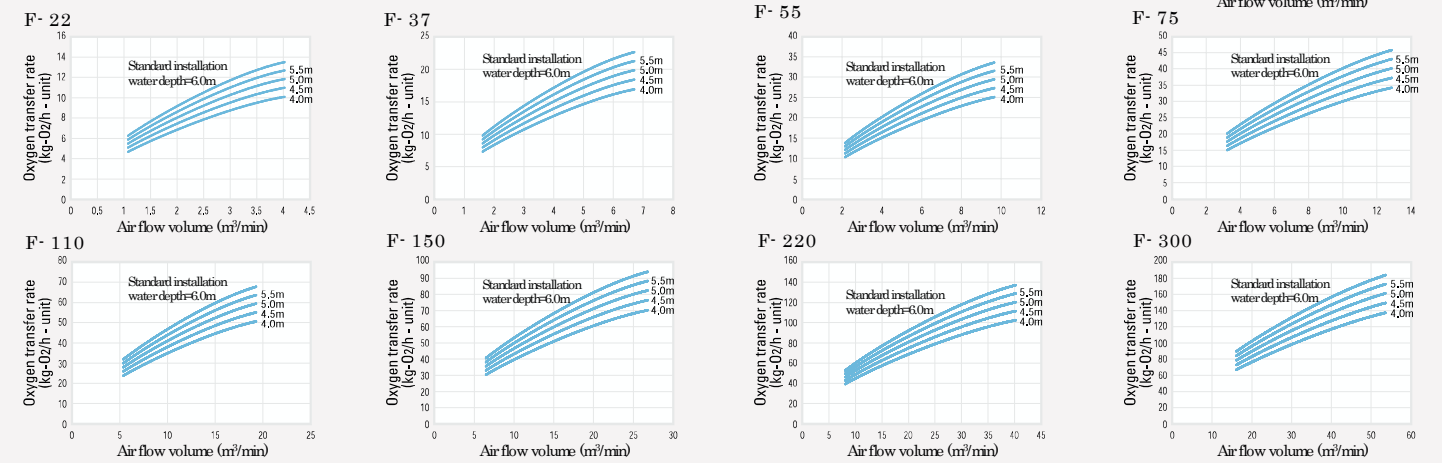

Oxygen transfer capability chart When operating on VWF

The following charts illustrate oxygen transfer rates when operating with revolution restrictions using a frequency converter at a standard installation water depth of 5.0m (freshwater 20°C, MLD0=0mg/L).
**"Rated revolutions" is the oxygen transfer rate while operating on commercial electrical power.
*Please use the following constants when performing calculations for when the standard installation water depth is other than 5.0m (4.0m · 0.85, 4.5m · 0.93, 5.5m · 1.07, 6.0m · 1.14).

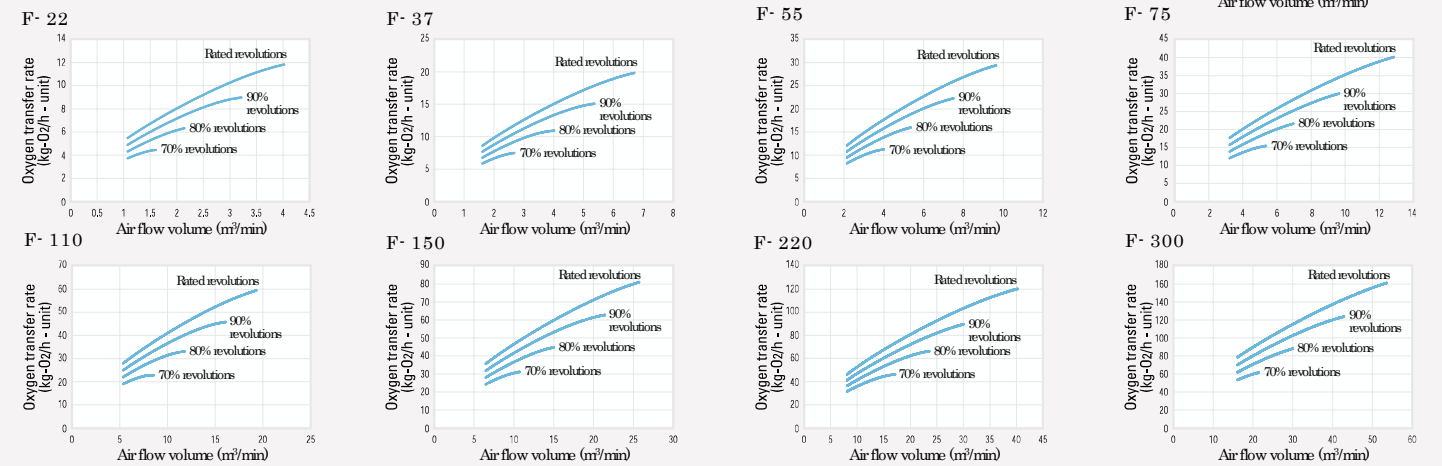

*Air flow volume is for standard conditions (20°C, 101.3kPa, 65%RH).
*Please consult HANSHIN ENGINEERING for water depths other than those above.

For an excellent water environment

Regular maintenance and repair

Due to its simple design, maintenance can be performed on-site and time required for maintenance can also be drastically reduced. Because the Aquarator is basically placed along a guide pipe, there is no need for water drainage when installing or removing the Aquarator. Appropriate maintenance cycles vary slightly depending on usage conditions. Please refer to the chart below and use them as a guide to perform maintenance according to the cycle, ahead of schedule if possible. Please note that pulling up the Aquarator from the tank approximately once a year and performing a visual inspection is highly effective in preventing malfunctions and maintaining life span.

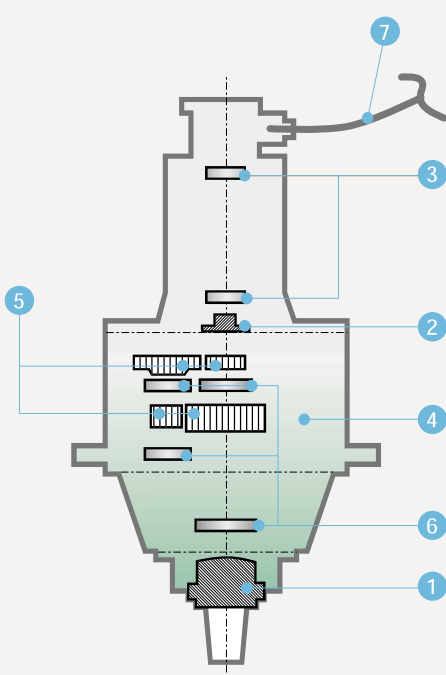
Part to be replaced	Recommended replacement cycle	Pertinent part to be replaced				Submerged drive mechanism schematics
		1st time	2nd time	3rd time	4th time	
Water seal cassette (for output shaft)	Every 3 years	○	○	○	○	 <ul style="list-style-type: none"> 1 Water seal cassette (for output shaft) 2 Oil seal cassette (for motor shaft) 3 Motor shaft bearings 4 Lubrication gear oil 5 Gears inside gear reducer 6 Bearings inside gear reducer 7 Cabtire cable
Oil seal cassette (for motor shaft)	//	○	○	○	○	
Bearings for motor shaft	//	○	○	○	○	
O-ring for joints	//	○	○	○	○	
Lubrication gear oil	//	○	○	○	○	
Gears inside gear reducer	Every 6-9 years			○		
Bearings inside gear reducer				○		
Cabtire cable						
Others						
Submerged motor	Depends on condition					
Submerged gear reducer						

*Please consult HANSHI ENGINEERING regarding regular maintenance and repair when using the Aquarator intermittently.

Cases of Aquarator application

Aquarator is suitable for all kinds of applications.

New/Standard Activated Sludge Process

Suitable to the following 4 patterns.

Pattern I O-O-O-O **Basic Pattern**

Pattern II A-O-O-O **Bulking Countermeasures**

Pattern III A-A-O-O **Nitrification Control** ASRT shortened

Pattern IV A-O-A-O **Nitrification Promotion** Nitrogen removal and BOD high cut down

Air Lift Circulating Nitrification/Denitrification Process

Single-Stage Nitrification/Denitrification Process

Dual-Stage Nitrification/Denitrification Process

Triple-Stage Nitrification/Denitrification Process

Intermittent Prolonged Aeration Process

24h/day

Excess sludge

Energy saving control

VVF

AS controller

MC

DO sensor

Auto flow available with ASRT control

3-Stage Anaerobic/Aerobic Process

Utilizing air lift circulation at terminal nitrification liquor

High level removal of BOD, nitrogen and phosphorus.

Deep Tanks

Draft tube

Sequencing Batch Reactor of Activated Sludge Process

1 cycle

Operating pattern I

Aerobification Settling Discharge

Operating pattern II

Agitation Stop

KF Type: Supernatant water discharger

Renovation of Installed Tanks

Bulking solution, nitrification control solution.

Air discharge level

*If air source is shared with other air dispersing equipment, the air intake level should be matched.

Sole Agent :



PT. LUMBUNG TEKNOLOGI ENVIROTAMA

KIRANA TWO OFFICE TOWER 17th - 18th FLOOR

Jl. Boulevard Timur No. 88 Kelapa Gading

Jakarta Utara 14240

Telp. : 021 - 2962 9767

Fax. : 021 - 2962 9769



阪神動力機械株式会社
HANSHIN ENGINEERING Co., Ltd.



Catalog No. 1561-02-3T